

# Church Specialties, Inc

68 Elaine Drive, Monroe, CT-06468, Tel 1-888-570-1042, Fax: 203-452-0107

## BELL SURVEY INSPECTION SHEET

Church: \_\_\_\_\_  
 Address: \_\_\_\_\_  
 City: \_\_\_\_\_ State: \_\_\_\_\_ Zip: \_\_\_\_\_  
 Contact Person: \_\_\_\_\_ Tel: \_\_\_\_\_  
 Email address: \_\_\_\_\_

***A photograph of the bell  
 would be helpful***

**If you have a Swinging Bell installation,  
 this is what should be checked:**

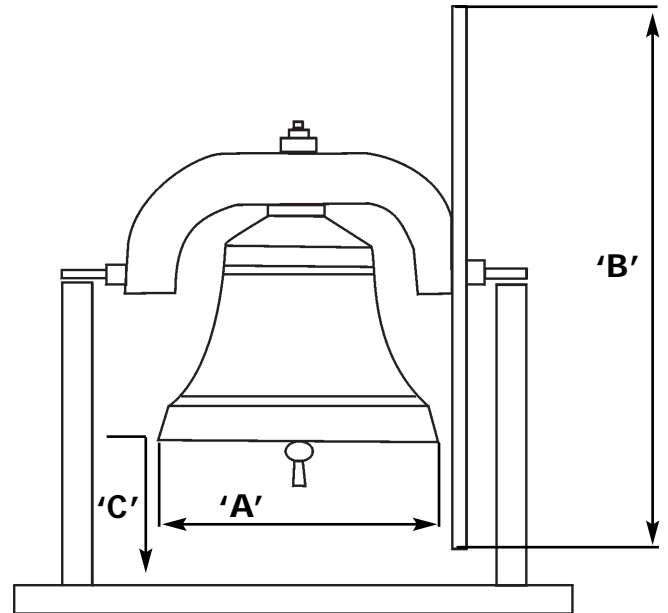
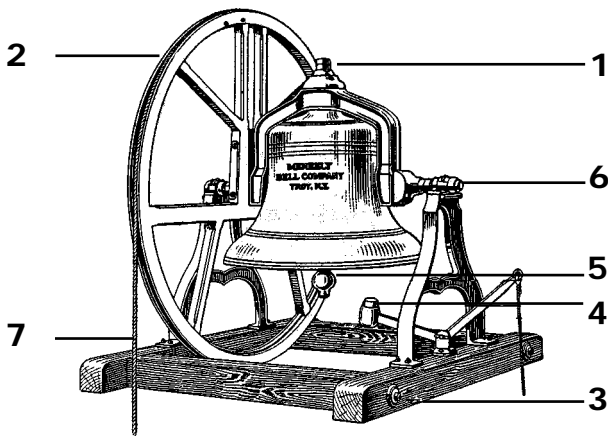

BELL: Foundry: \_\_\_\_\_

Date: \_\_\_\_\_

A. Diameter of Bell: \_\_\_\_\_

B. Diameter of Wheel: \_\_\_\_\_

C. Bottom of bell to  
 top of support beam: \_\_\_\_\_

- |   |  |          |                          |
|---|--|----------|--------------------------|
| 1. Bell loose in yoke.                  | Yes _____                                | No _____ | How many bolts _____     |
| 2. Wheel loose - pulling apart          | Yes _____                                | No _____ | Wood _____ Steel _____   |
| 3. Frame deteriorating                  | Yes _____                                | No _____ | Dimensions _____ x _____ |
| 4. Tolling hammer bent - loose fit      | Yes _____                                | No _____ |                          |
| 5. Clapper loose - spring leaves broken | Yes _____                                | No _____ |                          |
|   | Clapper Spring: Whole _____ Broken _____ |          |                          |
| 6. Axles worn and loose                 | Yes _____                                | No _____ |                          |
| 7. Rope rubbing on floor or projections | Yes _____                                | No _____ |                          |

General Comments: \_\_\_\_\_  
 \_\_\_\_\_  
 \_\_\_\_\_  
 \_\_\_\_\_